



User manual
MB-455 matte box
Version 1.0.1



Index:

Box contents MB-455 matte box:.....	2
Guide to components:.....	3
Common directions for using this matte box:	4
Hints for using this mattebox on wide angle lenses:.....	5
Adjusting the quick lock mechanism:.....	6
Accessories:.....	7
Contact data:.....	7

Box contents MB-455 matte box:

- Matte box MB-455.
- This manual.
- 1 pc. Top flag medium (#0430-0004).
- 1 pc. 121mm wide Filter frame 4"x5,65" (item #0410-0001).
- 1 pc. 150mm wide Filter frame combo 4"x4" / 4"x5,65" (item #0410-0002)
- 1 pc. 150mm wide Filter frame combo 5,65"x5,65" / 4"x5,65" (item #0410-0003)

Guide to components:

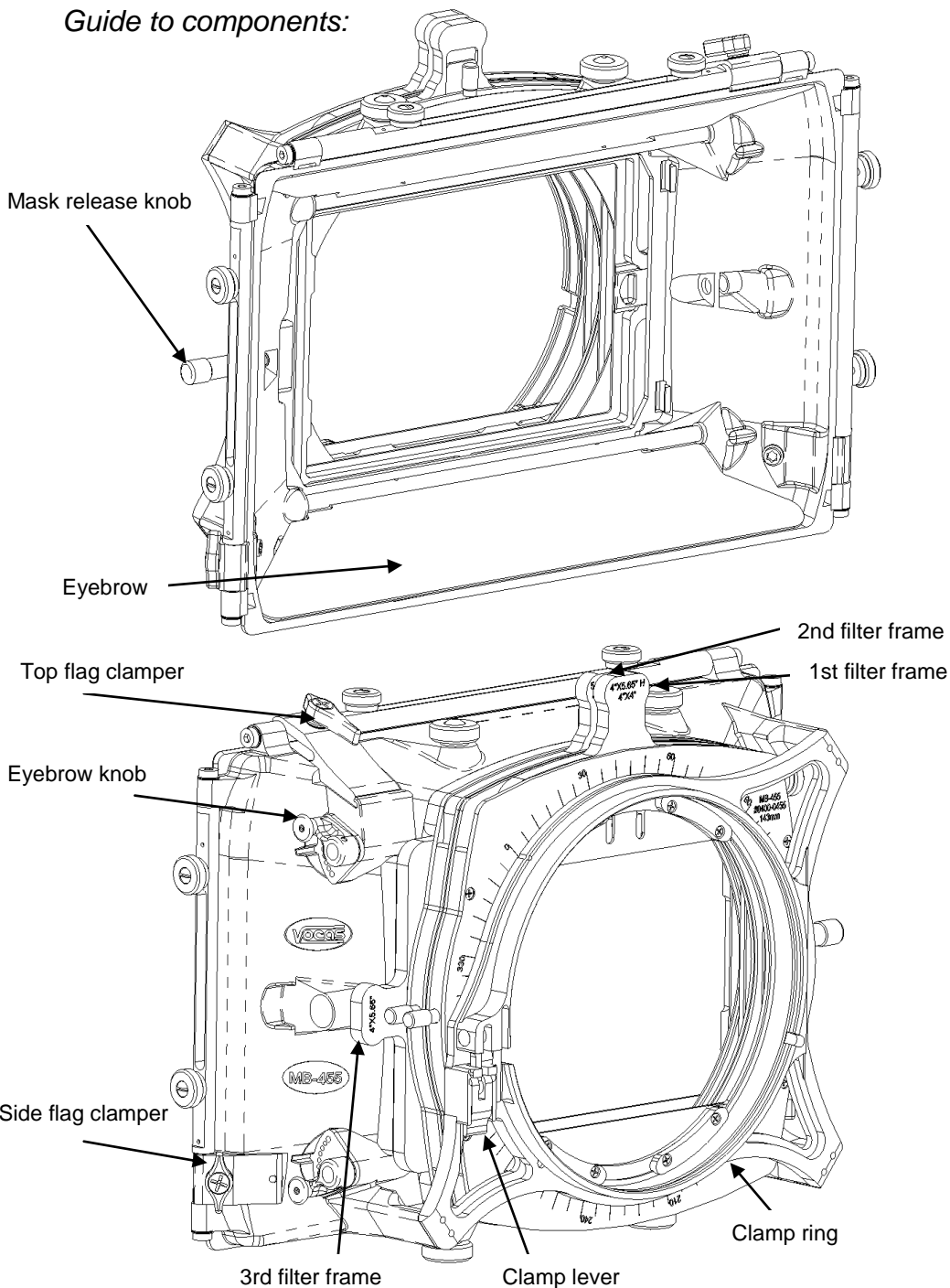

Common directions for using this matte box:

- This matte boxes can be attached to the camera in three ways:
 1. **Clip-on:**
For maximum lightweight and economical operation the matte box attaches directly to the front of a lens. Either with or without a step down adapter ring. The internal rear diameter of this matte boxes is 143mm.
 2. **15mm Bars adapter.**
This bars adapter attaches your matte box to any 15mm light weight rail support. Functionally connecting your matte box to the base of the camera.
 3. **On 15mm or 19mm swing away bracket**
The swing away bracket connects the matte box to either 15mm light weight or 19mm rails. As with the bars adapter this accessory connects the matte box to the base of the camera, however the swing away bracket also allows the user to quickly change lenses without having to remove the matte box from the rails.
- If the matte box is used on a rail support, we strongly recommend using the flexible adapter ring kit. This is a soft flexible step-down ring. To prevent light from entering from the rear side of the matte box (and reflecting via the filter in front of the lens), the hole in the flexible ring must match the front diameter of the used lens. Therefore the flexible ring can stretch to accommodate most lens diameters. This adapter ring can also house an additional 138mm round filter.
- For extra reduction of flare, the patented Eyebrows are added in the MB-455. These internal French flags can be adjusted to the zoom position of the lens by rotating the “eyebrow adjustment knobs”.
Caution: Not all viewfinders, LCD screens, and monitors show 100% of the captured image. Therefore, if the eyebrows are adjusted with the help of the LCD screen, it might be possible that the eyebrows come into picture.
- For maximum flair reduction a “Side flag kit” is also available for this matte box.

Hints for using this mattebox on wide angle lenses:

These hints are written especially for lenses that are 4,5mm or wider.

- Remove the 16:9 Mask, the 4th Filter holder or the Tilt filter from the front of the mattebox, because these will vignette.
- Do not use the 5th filter in the flexible adapter ring because this requires the mattebox to be further away from the lens, which will result in vignetting.
- The standard three filter-trays can be used without vignetting.
- All filter frames should be put in the mattebox with the type engraving facing the cameraman.

Adjusting the quick lock mechanism:

The quick lock mechanism is factory pre-adjusted, nevertheless is it possible that it clamps too tight or too loose on a lens. In this case perform the following steps:

1. Take the matte box of the lens.
2. Put the clammer in the "open" position.
3. Pull the clammer out of its housing as shown below.
4. Rotate the clammer right to tighten or left to loosen with halve a turn at the time.
5. Put the clammer back in its original position.
(note: please be careful not to over tighten the mechanism).

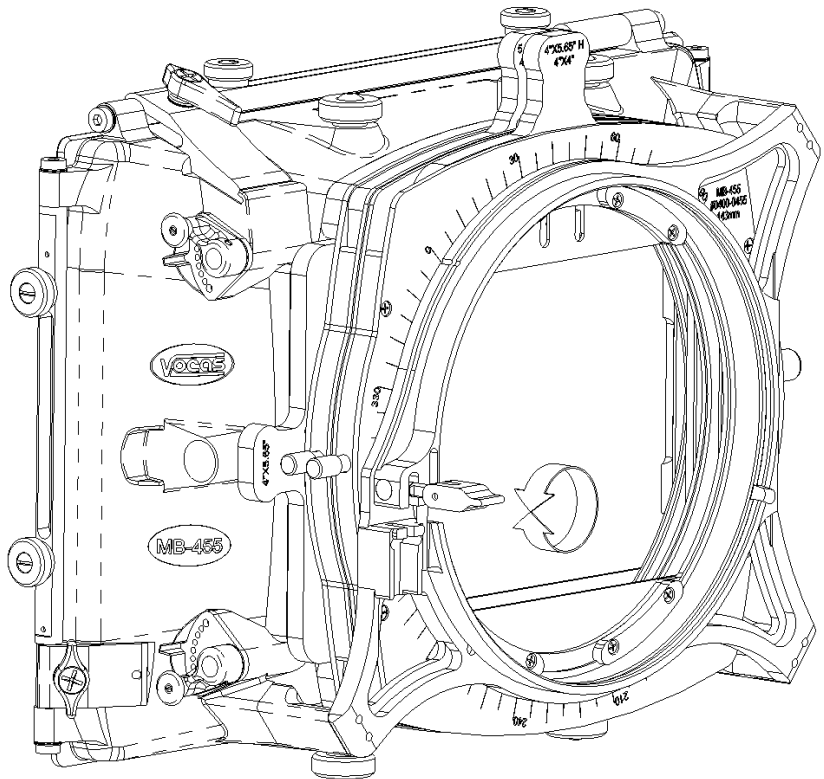

Accessories:

For all available accessories and compatibilities please check our website:
www.vocas.com

Contact data:

Vocas Systems B.V.
Larenseweg 121
1221 CL Hilversum-Netherlands
T:+31(0)35-6233707 F:+31(0)35-6233997
www.vocas.com

Like us on Facebook!
www.facebook.com/vocassystems

