

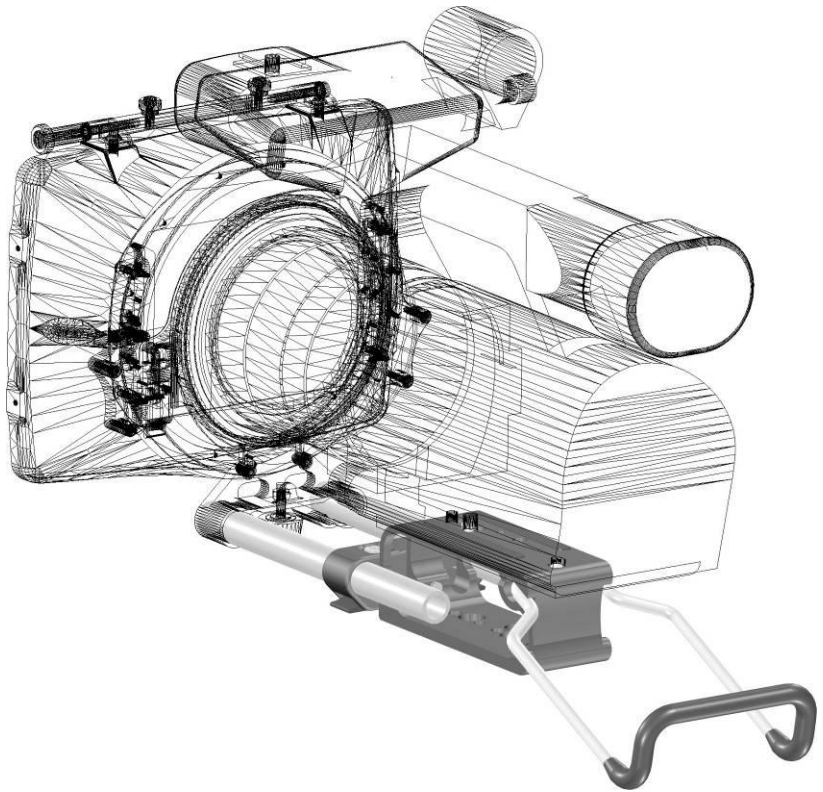

User manual
MBS-100 Type G4
Version 2.0.1



Index:

| | |
|--|----|
| Kit contents MBS-100 matte box support type G4 #0350-0012: | 2 |
| Fit chart: | 2 |
| Guide to components:..... | 3 |
| Common directions for using this matte box support: | 4 |
| Contact data:..... | 11 |

Kit contents MBS-100 matte box support type G4 #0350-0012:

- MBS-100 matte box support type G4.
- This manual.
- 2 pc. Bars 160mm.
- 1 pc. Hexagonal key 4mm.
- 1 pc. Alignment card.
- 1 pc. Shoulder support.

Fit chart:

This support is tested and approved on the following cameras:

- Sony PMW-EX1 / PMW-EX3
- Sony HVR-V1E / HDR-FX7
- Sony HVR-Z1U and Sony HDR-FX1
- Sony HVR-Z5E
- Sony PD-150 / 170
- Panasonic DVX-100 (AE)/ HVX-200
- Canon XH-G1/A1

Guide to components:

Top view

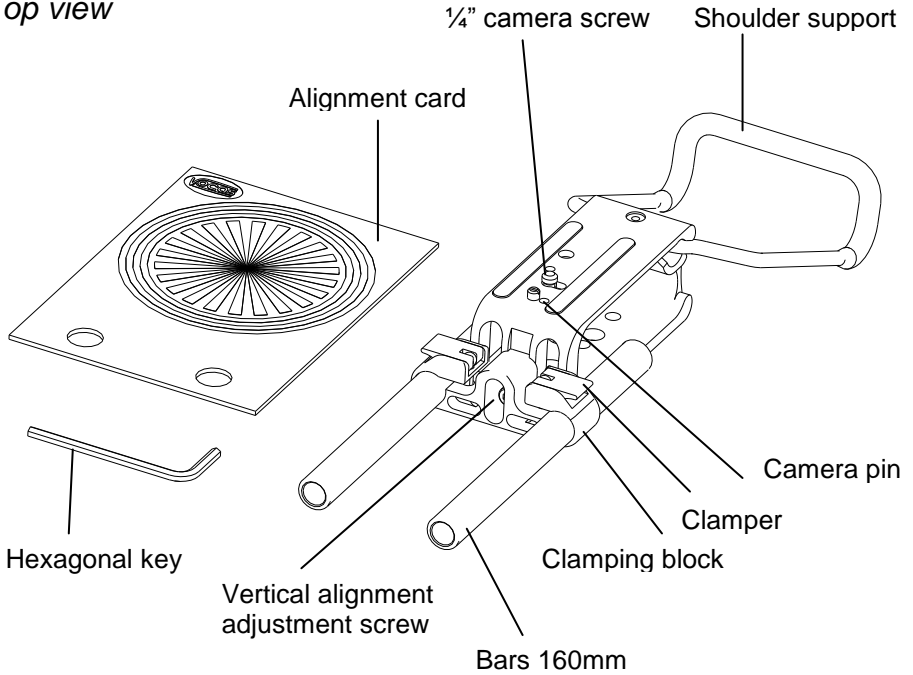

Common directions for using this matte box support:

How to unlock the bars:

If the bars have to be removed, simply flip up the clammer and remove the bar.

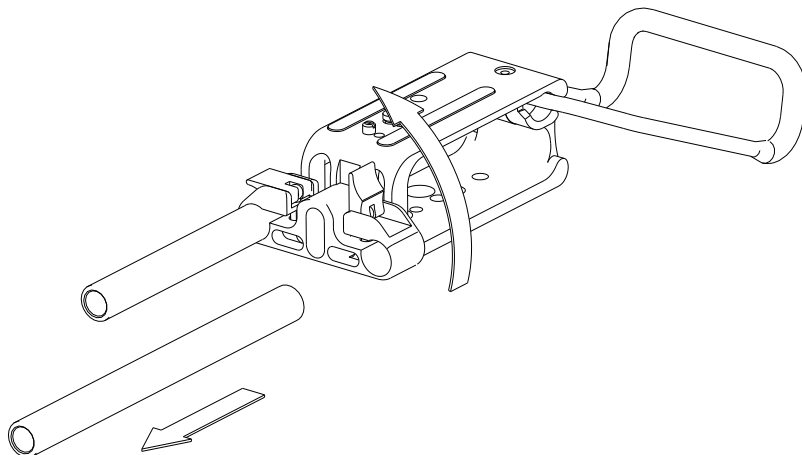

Attaching this support to the Sony HVR-V1E/HDR-FX7 and Sony PMW-EX1/EX3:

This support is factory pre-adjusted for the Sony HVR-V1E/HDR-FX7 and Sony PMW-EX1/EX3.

Attach the support to the camera as shown in the below illustration.

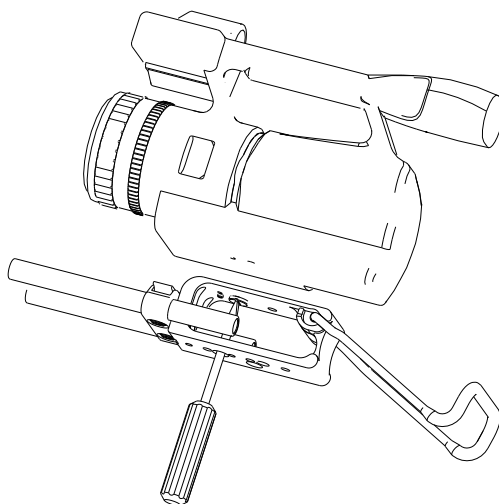

Attaching this support to the Panasonic HVX-200:

1. Remove the vertical alignment screw that is between the bars using the hexagonal key.

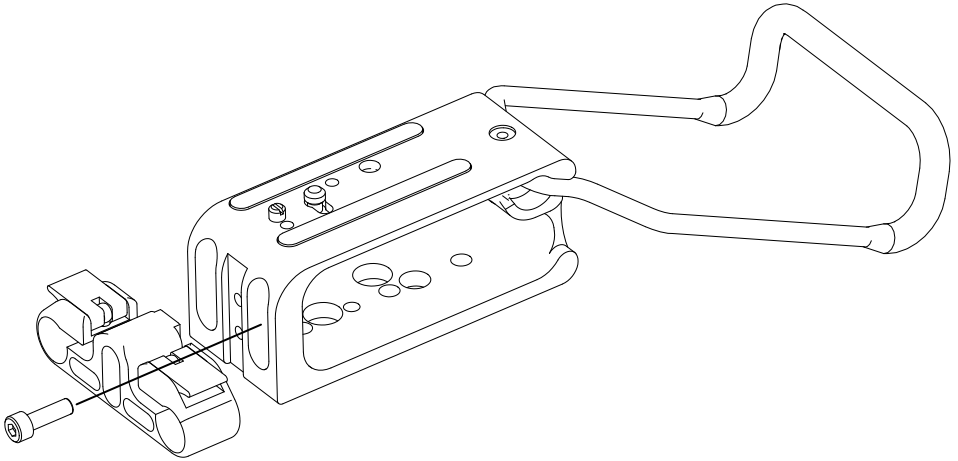

2. Rotate the clamping block 180 degrees and re-attach the vertical alignment screw in the top hole of the base plate using the hexagonal key as shown below.

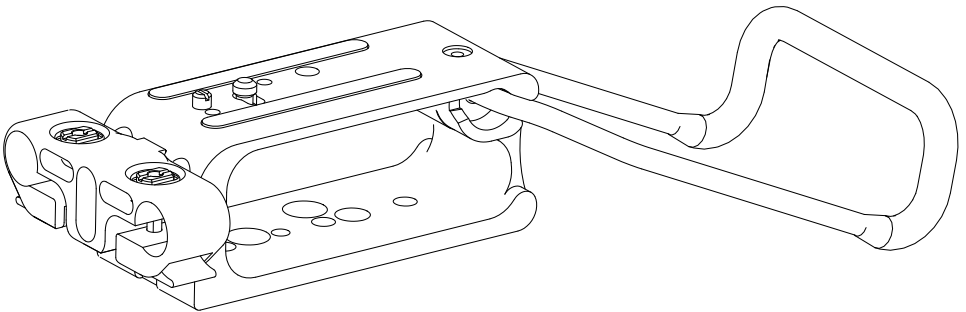

Attaching this support to the Canon XH-G1/A1 and Sony HVR-Z1U/HDR-FX1:

1. First remove the camera pin with a screwdriver.
2. Also remove the “vertical alignment adjustment screw” with the supplied hexagonal key.

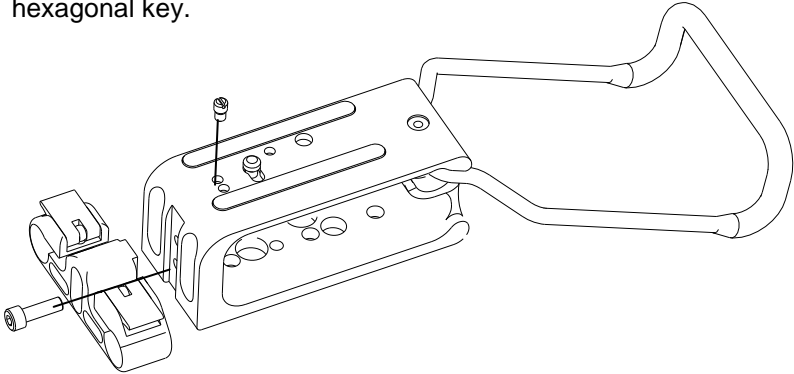

3. Rotate the clamping mechanism 180 degrees and reattach it to the baseplate (see illustration below).
4. Also reattach the camera pin as shown in the below illustration (for the Sony Z1U/FX1 cameras you can also use the rear hole for even better fixation).

Rear hole for Sony Z1U/FX1

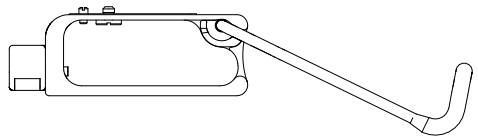
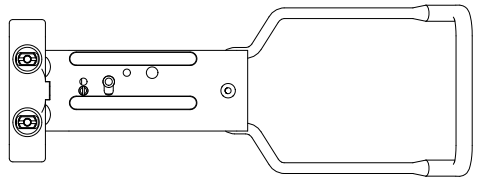
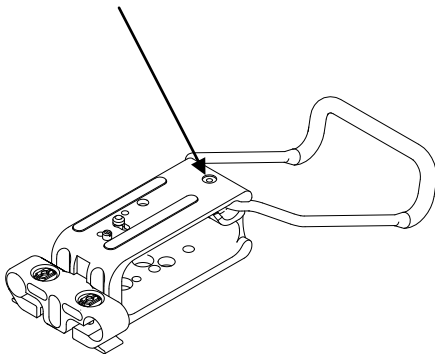

Attaching this support to the DVX-100 and Sony HVR-Z5E

1. Remove the camera pin and the ¼" camera screw with a screwdriver.
2. Also remove the "vertical alignment adjustment screw" with the supplied hexagonal key.

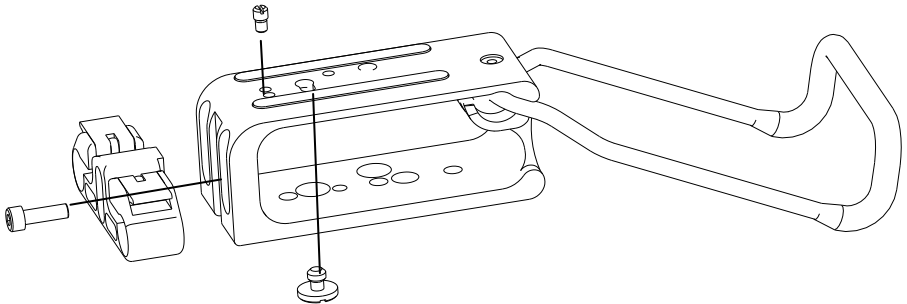

3. Rotate the clamping mechanism 180 degrees and reattach it to the baseplate (see illustration below).
4. Also reattach the camera pin and ¼" screw as shown in the below illustration

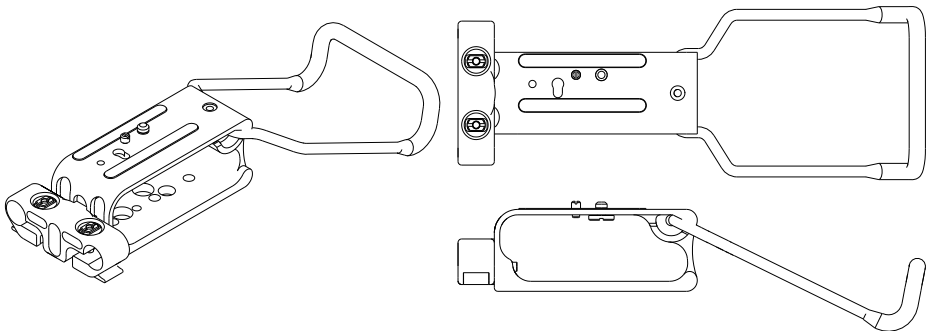

How to adjust the alignment of the support:

For proper alignment of the tubes, the support can be adjusted in the vertical direction.

Unscrew the “vertical alignment adjustment screw” for a half turn, (with the supplied hexagonal key) and move the clamping block to the desired height.

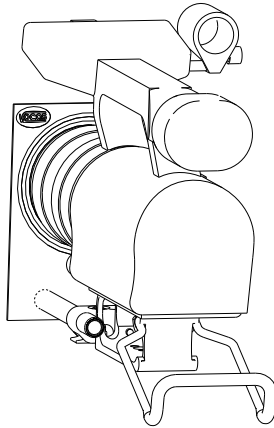

To check the proper alignment, the supplied “Alignment card” can be used. Slide the two holes in the card over the two installed 15mm tubes and check if the lens front corresponds with the big circles on the Alignment card. The alignment card can also be used as a back focus- or white card.

How to use the shoulder support:

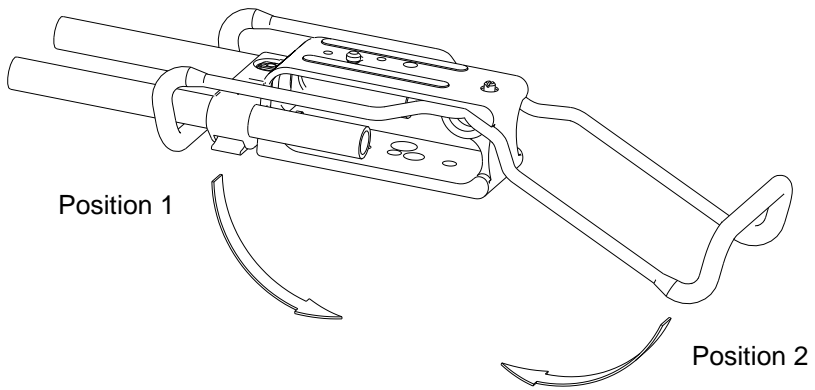

The included shoulder support can be used in two positions. Placing the shoulder support in either position can be done by simply pushing or pulling the rubberized part in either direction. The two positions are illustrated in the figure below:

How to adjust the clamping mechanism:

The clamping mechanism can be readjusted for a tighter or looser grip on the bars:

1. Flip up the clamber.
2. Remove the 15mm bar.
3. To release the clamp nut, push the clamber upwards, in the direction of the Clamp nut.
4. Rotate the Clamp nut clockwise to tighten, or counter clockwise to loosen the mechanism

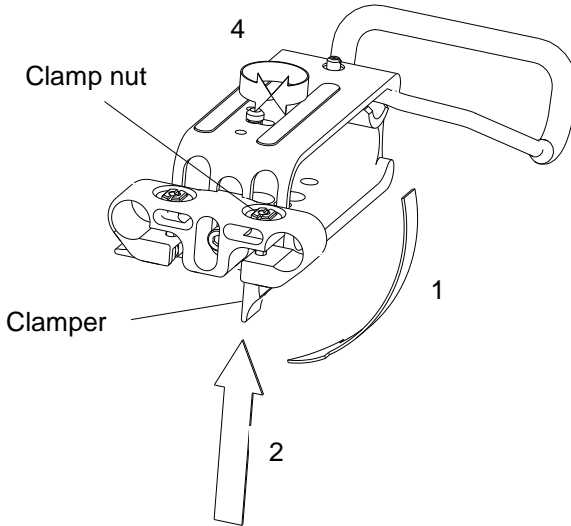

Contact data:

Vocas Systems B.V.
Larenseweg 121
1221 CL Hilversum-Netherlands
T:+31(0)35-6233707 F:+31(0)35-6233997
www.vocas.com